

## PATIENT INSTRUCTIONS

### Dynasplint® Ankle Plantar Flexion System Type II

Corporate Headquarters:  
**800.638.6771** toll-free  
**800.380.3784** fax

Canada:  
**800.668.9139** toll-free  
**905.851.3494** fax

Europe:  
**00131.455 230 418** phone  
**00131.455 231 303** fax

**www.dynasplint.com**

**IMPORTANT:** Read instructions thoroughly before wearing the Dynasplint® Ankle Plantar Flexion System. Be sure that the splint fits comfortably and properly. If you feel pain, numbness, swelling, or skin irritation remove the splint immediately and contact your Dynasplint® Systems sales consultant. If joint stiffness persists longer than one hour after wearing the unit, reduce the tension by 0.5 increments or approximately  $1/2$  turn. Contact your Dynasplint® Systems sales consultant if you have any questions.

DYNASPLINT® and Dynasplint® Systems are registered trademarks of Dynasplint Systems, Inc.



*Stretch Beyond Your Expectations.®*



## FITTING INSTRUCTIONS

### APPLYING THE DYNASPLINT® ANKLE PLANTAR FLEXION SYSTEM:

If possible, you should sit at the edge of a chair or bed with foot flat on floor.

**STEP 1:** While seated, open the calf cuff and loosen the counterforce strap. See Figure 1.

**FIGURE 1.**

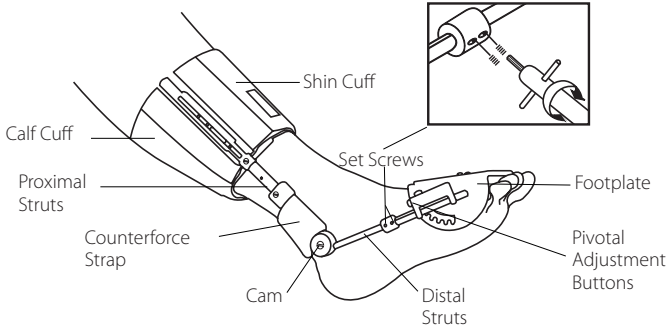

**STEP 2:** Slide the foot over the counterforce strap so that the top of the foot is centered below the footplate. See Figure 1.

**STEP 3:** Close the calf cuff and tighten the counterforce strap.

**STEP 4:** Check the alignment. See Figures 1 & 2. The struts (tubes) should line up with the centers of the sides of the leg, and the cams should be lined up with the ankle bones at the centers of the sides of the ankle.

**FIGURE 2.**

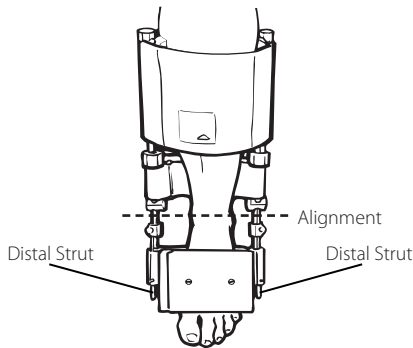

**STEP 5:** Check cuff for tightness. You should be able to slide a finger between your leg and the Dynasplint® System cuffs.

**STEP 6:** Do not tamper with shin cuff.

**STEP 7:** You should be inactive and relaxed while wearing the Dynasplint® System. The splinted leg should not hang downward. Elevate the splinted leg in a supported position under the calf or ankle, supporting the calf and knee by using a pillow.

## REMOVING THE DYNASPLINT® ANKLE PLANTAR FLEXION SYSTEM:

**STEP 1:** Completely open the calf cuff and loosen the counterforce strap.

**STEP 2:** Remove leg from splint.

Continue to follow your physician's or therapist's instructions regarding your home therapy program while wearing the Dynasplint® System. Record your comments daily on the evaluation sheet (back page of booklet) for review with your Dynasplint® Systems sales consultant.

## CLINICIAN'S PRESCRIBED TREATMENT SCHEDULE

*These are guidelines only. Remove the Dynasplint® System if you experience pain at any time and contact your Dynasplint® Systems sales consultant.*

Tension to be initially set at \_\_\_\_\_ increments.

Patient will wear the Dynasplint® System for \_\_\_\_\_ hours the first day.

If no more than one hour post-wear discomfort occurs, the patient may increase wear time over a 2-3 day time period, building up to overnight application of 6-8 hours. Time spent wearing the splint is the most important component in regaining range of motion.

Increase tension by 0.5 increments or approximately  $\frac{1}{2}$  turn on both sides of the splint if less than one hour of post-wear discomfort occurs.

Decrease tension if unable to wear for extended period of time.

Maximum tension: \_\_\_\_\_ .

The basic protocol outline is to provide maximum benefit from the Dynasplint® System. *Increasing tension faster does not ensure proper stretch will be applied.*

Remember to wear the Dynasplint® System while inactive, preferably while sleeping. If unable to sleep in the splint, maximize wear time during the day.

Your follow-up visit is \_\_\_\_\_ .

Please bring the Dynasplint® System and the completed evaluation sheet.

Sales Consultant: \_\_\_\_\_ Voicemail Number: \_\_\_\_\_

